

Attachment of locator and jig

- In the case of attaching the locator and the jig on the chuck body surface, tap or drill a hole in the additional process range specified in Fig. 18.

Shaded part additional process possible range

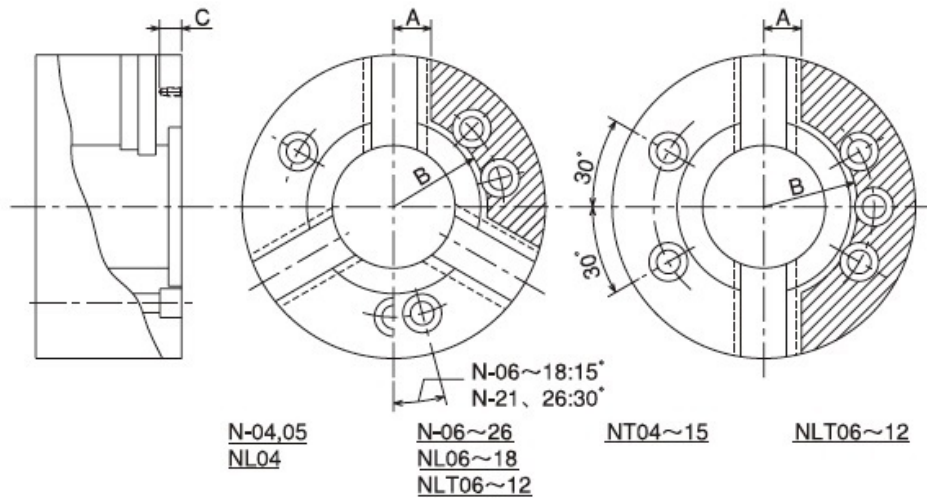

Fig.18

Table 9

Type	A (mm)	B (mm)	C (mm)
N-04, NL04, NT04	22	37	15 or less
N-05, NT05	22	44	15 or less
N-06, NL06, NLT06	26	55	20 or less
N-08, NL08, NLT08	29	60	20 or less
N-10, NL10, NLT10	34	67	20 or less
N-12, NL12, NLT12	40	80	20 or less
N-15, NT15	53	90	30 or less
N-18, NL18	53	119	30 or less
N-21	53	98	30 or less
N-24	53	137	30 or less

A, B: Additional process impossible dimension. C: Processible depth of tapping or drilling a hole.

! DANGER

- The chuck can be modified only in the manufacturer permissible range. This will not only break the chuck but the chuck and work may fly out, which is dangerous.
- Provide a countermeasure against flying out (dwell pin, etc.) due to centrifugal force to the locator or the jig, and attach with bolts which have sufficient strength. The locator or the jig may fly out, and this is dangerous.